

Patient's Vital Sign Monitoring System Using Wireless Personal Area Network

Pradnya Kamble¹, Prerana Ghosh², Aparna Gole³, Priyanjali Manore⁴
& Rahul Bhanushali⁵

¹Asst. Professor, dept. of Electronics & Telecommunication engineering, K.J.Somaiya Inst. Of engineering & Information Technology

^{2,3,4,5} Student, dept. of Electronics & Telecommunication engineering, K.J.Somaiya Inst. Of engineering & Information Technology

Abstract: Health care monitoring system has drawn considerable attentions for the last decade. As the population is increasing and at the same time the health care cost is skyrocketing there has been a need to monitor a patient from each nook and corner of the world. The main job is to accurately measure, record and analyze patients' data. In this project we present a ZigBee based wireless healthcare monitoring system. This system uses the low power ZigBee wireless trans-reception technology along with an Arduino based microcontroller. Vital health signs like heart rate and Blood Pressure can be monitored in real time using this system. Monitoring is done at a central node which is connected in a Star topology with the wireless patient modules. The aim of the project is to develop and implement the health care monitoring using wireless sensor network.

Keywords: ZigBee, Wireless Sensor Network, Health, Heart rate sensor, Blood pressure sensor, Temperature sensor

1. Introduction

Nowadays, the average lifespan has increased due to the improvement of medical field and as a result of an increase of the disabled population for aged people. In addition, due to social development, the number of disabilities as a result of various diseases or due to accidents is increasing. For this reason, a simple but efficient system is required to monitor the conditions of patient continuously [1]. The current monitoring systems used by hospitals are mostly based on cable connections. The size and power consumption are often too large and not easy to carry. Remote and wireless health care at home or in the hospital is an important technology with many advantages. Firstly, people can monitor their physiological Parameters at home without the necessity to go to the hospital from time to time; Secondly, people who carry the sensing devices can move around freely without the obstacle from

complex connecting cables; and finally, doctors in the remote server centre can watch the patient's health condition closely and hence provide real-time advices for the patients' recovery and long-term care.

2. System Overview

We have hence proposed the system that consists of two parts mainly- The patient side module and the observing module of which the latter will be a database consisting of vital health related data. The hardware involved in implementation of the system uses an Arduino along with ZigBee module which is created by Digi International [2, 3]. The sensors will send analog data that will be sensed by the ADC of the Arduino and calibrated data will be sent over the ZigBee's wireless channel. It is decided that to make the WSN robust and simple the topology used will be Star topology where one node is connected to a central monitoring node. Fig 1 illustrates the Architecture of the proposed system. A more robust and fail system proof can be achieved by using the mesh topology. However as the system is in its early stage of development a basic star topology will be favourable for its implementation.

The hardware used in the implementation of system is minimal which consists of three major components which is the ZigBee Module, the Arduino and the analog sensors. The following Section will provide some details about the analog sensors that will be used.

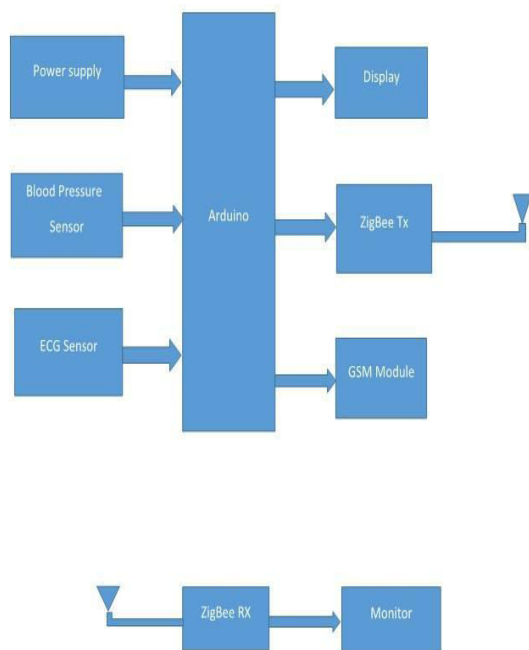

Figure 1. System architecture of wireless health monitoring system using ZigBee

3. Hardware and software design

The hardware used in the implementation of system is minimal which consists of three major components which is the ZigBee module [4, 5], the Arduino based micro-controller and the analog sensors. The following Section will provide some details about the analog sensors that will be used in the system.

3.1. Heart Rate Sensor

The system consists of an infrared (IR) LED as transmitter and an IR photo-transistor as a receiver that acts as a fingertip sensor. The sensor consists of a super bright red LED and light detector. The LED needs to be super bright as the maximum light must pass spread in finger and detected by detector. Now, when the heart pumps a pulse of blood through the blood vessels, the finger becomes slightly more opaque and so less light reached the detector. With each heart pulse the detector signal varies. This variation is converted to electrical pulse. This signal is amplified through an amplifier which outputs analog voltage between 0 to 5V logic level signal.

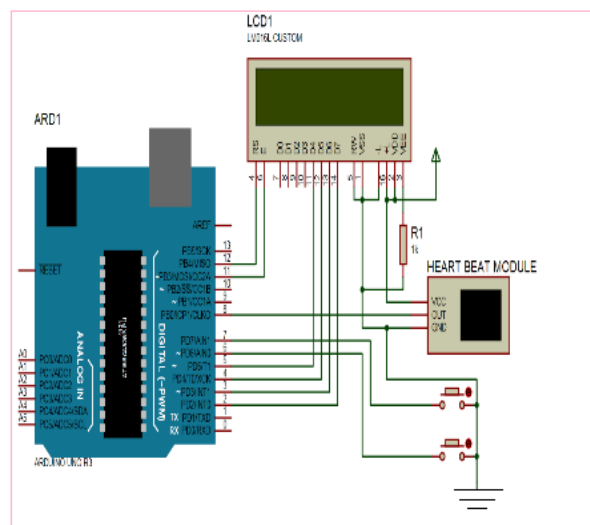

Figure 2. Interfacing of heart rate sensor with Arduino

3.2. Blood Pressure Sensor (BMP180)

The Blood Pressure Sensor is a non-invasive sensor designed to measure human blood pressure. It measures systolic, diastolic and mean arterial pressure utilizing the sociometrist technique. You probably have high blood pressure (hypertension) if your blood pressure readings are consistently 140 over 90, or higher, over a number of weeks. You may also have high blood pressure if just one of the numbers is higher than it should be over a number of weeks. If you have high blood pressure, this higher pressure puts extra strain on your heart and blood vessels. Over time, this extra strain increases your risk of a heart attack or stroke. High blood pressure can also cause heart and kidney disease, and is closely linked to some forms of dementia.

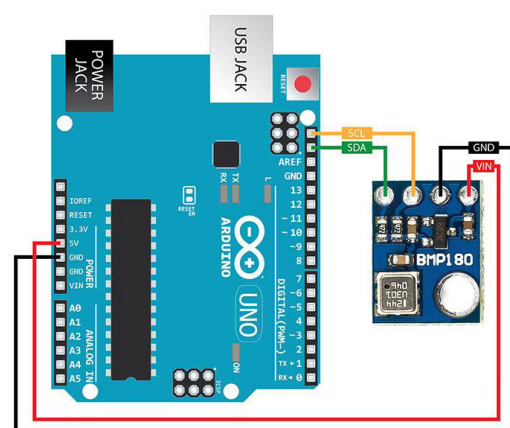

Figure 3. Interfacing of BMP180 blood pressure sensor with Arduino

