

# Design of Automatic & Indigenous E-Cradle

<sup>1</sup>Nitin Bhatnagar, <sup>2</sup>Kshitij Shinghal, <sup>3</sup>Amit Saxena, <sup>4</sup>Niket Tiwari,  
<sup>5</sup>Shubham Bhatnagar, <sup>6</sup>Shushant Kumar

<sup>1,4,5,6</sup>UG Scholars, <sup>2</sup>Associate Professor and Head, <sup>3</sup>Assistant Professor  
Department of Electronics & Communication Engineering, Moradabad Institute of  
Technology, Moradabad

**Abstract :** Money, Fame & Profession are some of the aspects that does not allow a person to live an easy life. Today, a people are so busy that they does not even get time for their families. Today, even women are working. Thus, it has become a common problem for the babies at the home, as they does not get enough time from their parents. Although, a lot of cradles are available in the market but they have to be swayed manually. Therefore, a need of automatic cradle has occurred. Following paper defines a low cost indigenous design for E-Cradle.

## 1. Introduction

In today's fast paced life, Parents are busy in their professional life everyone is busy in its own life. Nowadays, even the mothers are working, it sometimes become a problem for parents and nurses to look after the infants, so they do not get sufficient time to take care of their babies. . It may be expensive for the household to afford a nanny. Today's woman has to manage home along with their office work simultaneously. After long working hours, they have to take care of the home along with the baby. They may not get enough time to swing the cradle manually and sooth the baby. Moreover, in today's life style, it is very difficult even for the housewives to sit nearby their infants and sooth them whenever they cry.

Hospitals have neonatal and maternity units. Nurses in these units have to take care of baby and sooth them whenever they cry.

Hence, it has become a need to develop a new automatic electronic cradle, as, existing cradles are to be swayed manually. The proposed E-Cradle is a novel solution to this problem. E-Cradle swings automatically when baby cries, for this it has a microphone detects the baby cry voice and accordingly the cradle swings till the baby stops crying and also checks whether the mattress is wet or not. The system is provided with an alarm that indicates two conditions – first when the mattress is wet, which is an important parameter to keep the baby in hygienic condition, second when

baby does not stop crying with in a stipulated time of 2 min, which intimates that baby needs attention. This system helps parents and nurses to take care of babies without physical attention.

In the proposed design, there will be a circuit placed along the cradle which will sense the sound intensity of the cry of the child and takes necessary actions based on the sound intensity of the child's cry.

The system is designed to help parents and nurses in infants care. The design aims at following points:

1. Cradle starts swinging automatically when baby cry.
2. If the baby stops crying before 2 minutes, then the cradle will stop automatically after 3 minutes of swinging.
3. Sounds an alarm if baby cries for more than a stipulated time of 2 minutes indicating that baby needs attention.
4. Sounds an alarm when mattress gets wet.

Looking after babies is hard problem worldwide. Babies are society future. This system emphasizes the importance of child care. This system is economical and user friendly and very useful for working parents and nurses. They can manage their work efficiently.

## 2. Working Of E-Cradle

### Block Diagram

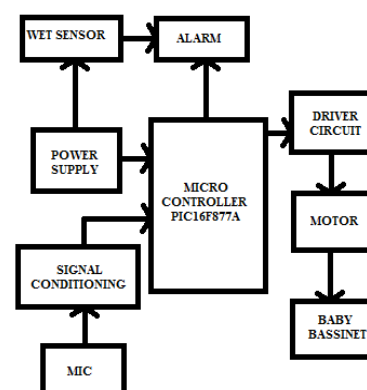

Figure 1 Block Diagram of E-Cradle

- **MIC:** When baby cries in the cradle, microphone detects it and converts the sound signal into electrical signal. The electrical signal is then fed into amplifier.
- **Signal Conditioning:** Signal amplification is done here. Op-amp is used as amplifier for signal conditioning circuit. The electrical signal from MIC is provided as input to the circuit. The output from MIC is amplified by op-amp so that it can be used by microcontroller.
- **Microcontroller:** PIC16F877A is used to receive the amplified signal and convert this amplified signal to digital signal. Microcontroller controls the driver circuit that starts a motor and sways the baby bassinet. Microcontroller also controls the buzzing of alarm when the motor sways the bassinet for more than two minutes.
- **Driver Circuit:** Motor driver circuit consists L293D IC, which supplies essential power to drive the motor. This isolates the PIC and ICs from electrical problems.
- **Motor:** DC motor of 60 RPM, 12 volts, 1A is used to sway the baby bassinet. It is connected to PIC through a driver circuit.
- **Wet Sensor:** It is a moisture sensor having two leads in mesh form. When baby wets the mattresses the two leads become short and signal is sent to the alarm. This system helps in keeping the baby in a hygienic environment.
- **Alarm:** Alarm will be generated on two conditions:
  - When mattress is wet, indicating parents that mattress and baby clothes need to be changed.
  - When baby cries for a specific time. For example, baby cries and baby bassinet swings for 2 min alarm will be generated. This indicates parents that baby needs attention
- **Baby Bassinet:** Baby bassinet is the infant bed. This is connected to a motor which sways the baby bassinet based on the power it receives from the driver circuit.

3. Take voice of the baby's cry as the input 'x'
  4. If (x>y)
    - 4.1 Swing the Cradle
    - 4.2 If Cradle Swing Time >= 2min
      - 4.2.1 If (x>y)
        - 4.2.1.1 Sound the Alarm
      - 4.2.2 Else Swing Cradle for 1 more minute
  5. Go to Step 4
  6. Stop
- **For Mattress Wet Alarm**
    1. Start
    2. If Mattress is Wet
      - 2.1 Sound the Alarm
    3. Go to Step 2
    4. Stop

### Flow Chart

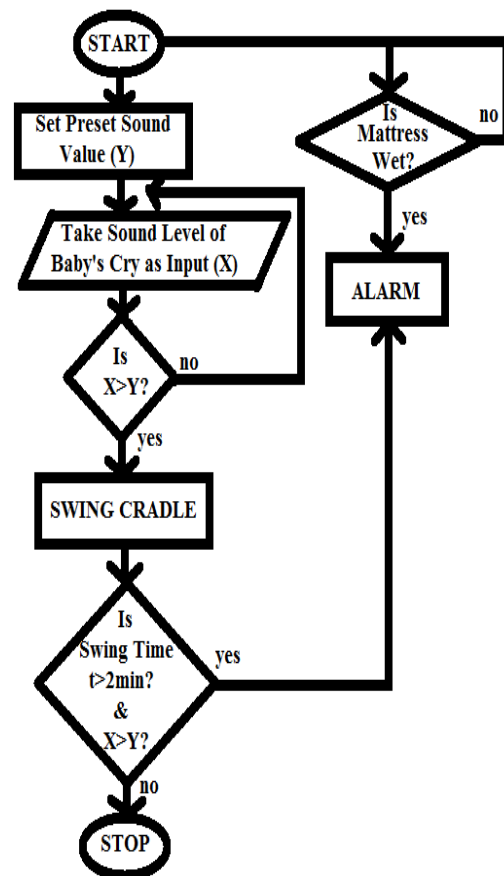

Figure 2 Flow Chart

### Working

- **Swinging the Cradle**

The device keeps on comparing the baby's cry generated sound level in dB x with a preset value y and it swings if x is greater than y.

The amplified signal is generated from the voice input. This amplified signal is then converted into a digital signal from which sound level  $x$  is calculated.

$$\text{Sound Level } x = 20 \log V_{in}/V_0 \text{ dB}$$

Where,

$V_{in}$  = Voltage (ADC count) when baby is crying.

$V_0$  = Average Reference Voltage (ADC count) when baby is not crying.

The preset value  $y$  is set initially as part of configuration of the system.

This sound level in dB is compared with the preset value of the device. If it is higher than the preset value then a logic high is sent to the driver circuit, thus driving the motor.

This motor is attached to the cradle with a thread such that with each rotation of the motor, the cradle is pulled and pushed in the continuous half rotation of the motor's shaft.

The motor swings the cradle for 2 minutes and again if the baby is found to be crying, then an alarm is buzzed so as to intimate the parents that the baby needs their attention.

Otherwise, if after 2 minutes, the baby is found to be quiet, then after one more minute of swinging, the cradle will stop automatically.

Above process keeps on repeating continuously.

- **Mattress Wet Alarm**

For checking whether the mattress of child is wet or not, an electronic plate is kept under the child's mattress. Whenever, the mattress gets wet, it completes the electronic circuit of the plate and thus sounding the alarm.

### 3. Circuit Diagram

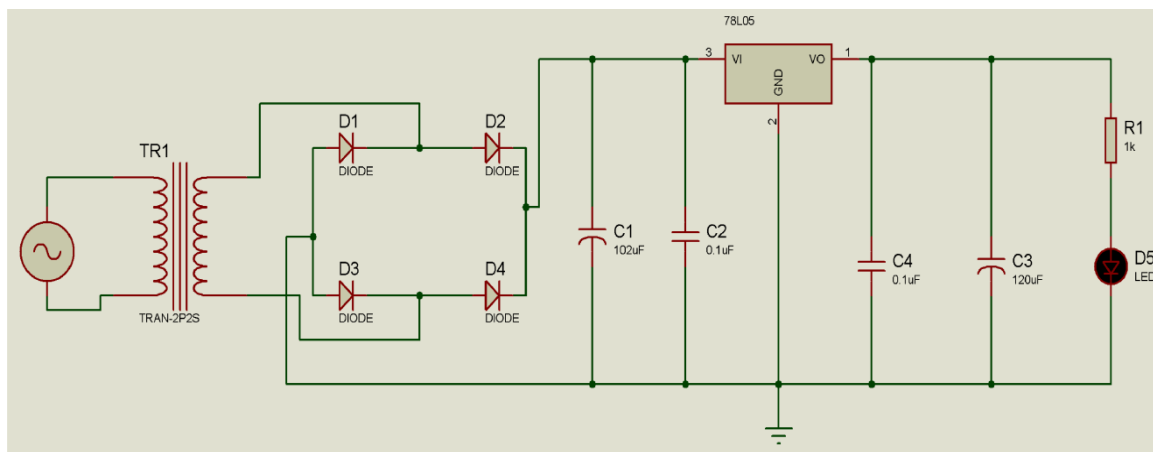

Figure 3 Circuit Diagram of Power Supply

Figure 3 depicts the power supply of the system. The circuit uses standard power supply comprising of a step-down transformer from 230V to 12V and 4 diodes forming a bridge rectifier that delivers pulsating dc which is then filtered by an electrolytic capacitor of about 470µF to 1000µF. The filtered dc being unregulated, IC LM7805 is used to get 5V DC constant at its pin no 3 irrespective of input DC varying from 7V to 15V. The input dc shall be varying in the event of input

ac at 230volts section varies from 160V to 270V in the ratio of the transformer primary voltage  $V_1$  to secondary voltage  $V_2$  governed by the formula  $V_1/V_2 = N_1/N_2$ . As  $N_1/N_2$  i.e. no. of turns in the primary to the no. of turns in the secondary remains unchanged  $V_2$  is directly proportional to  $V_1$ . Thus if the transformer delivers 12V at 220V input it will give 8.72V at 160V. Similarly at 270V it will give 14.72V. Thus the dc voltage at the input of the regulator changes from about 8V to 15V because of

A.C voltage variation from 160V to 270V the regulator output will remain constant at 5V. The regulated 5V DC is further filtered by a small electrolytic capacitor of 10 $\mu$ F for any noise so generated by the circuit. One LED is connected of this 5V point in series with a current limiting resistor of 330 $\Omega$  to the ground i.e., negative voltage to indicate 5V power supply availability. The unregulated 12V point is used for other applications as and when required.

Figure 4 depicts the circuit diagram of wet sensor used in the system, comprising of two 1k resistors, an NPN transistor and an alarm. The two sensor probes are connected to a mesh which sounds an alarm when the circuit gets completed by the water.

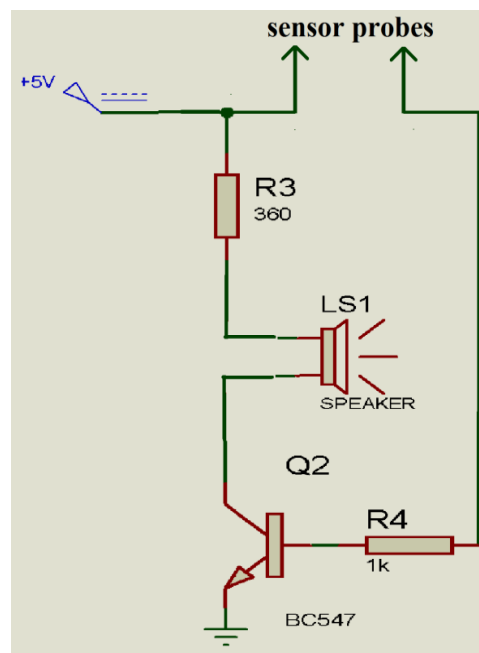

Figure 4 Circuit Diagram of Wet Sensor

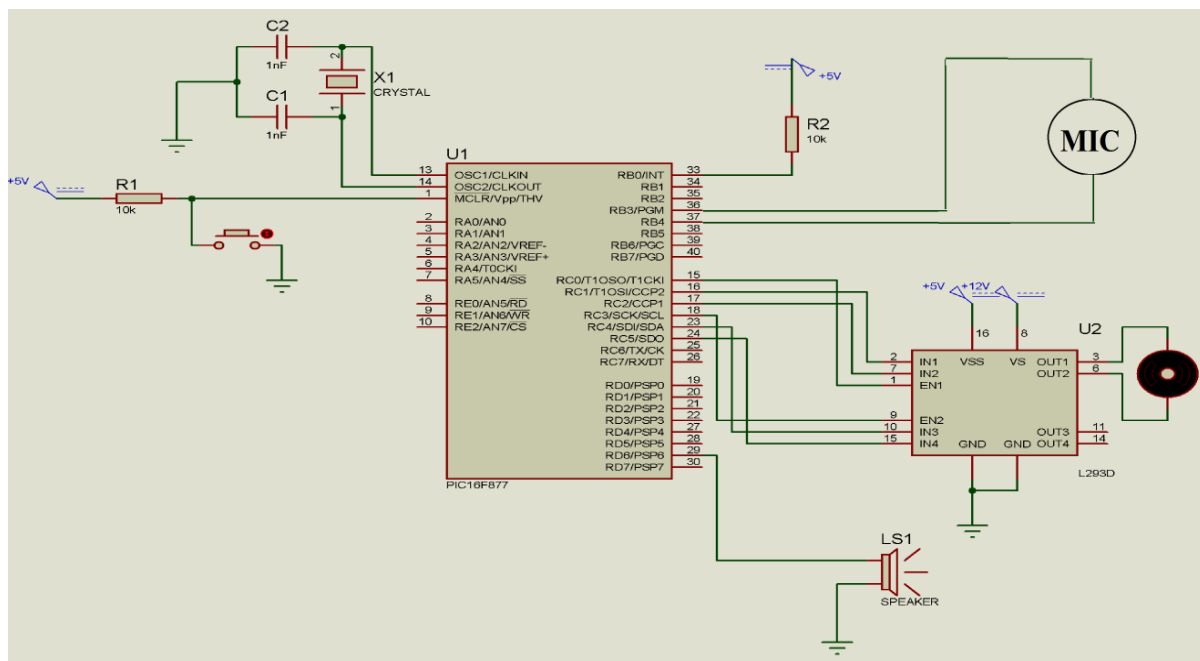

Figure 5 Circuit Diagram of E-Cradle

Figure 5 depicts the main circuit of the system, comprising of PIC 16F877A, MIC, L293D and Buzzer. PIC 16F877A is the main controller of the circuit, which gets the input from the microphone and compares the input with the preset value. If the input is greater than the preset value then it sends the high voltage to the Driver Circuit of L293D

which ultimately turns on the motor for swaying the cradle.

#### 4. Result And Discussion

Minimum sound level of baby's cry was found to be 20 dB. The system is programmed in such a way that it moves the motor of the cradle when the microphone gets the sound of more than 20 dB and if the baby stops crying before 2 minutes then will continue to sway for a total of 3 minutes, so that the baby feels cozy and sleeps properly. Else if, the baby does not stop crying for 2 minutes then it will sound the alarm, indicating that the baby needs attention.

Following are the pictures of working E-Cradle:



Figure6E-Cradle



Figure 7 Wet Sensing Mesh



Figure 8 Sound Sensing Module

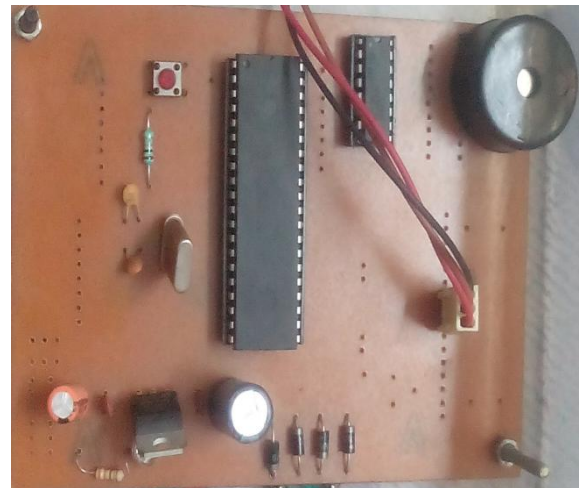

Figure 9 Main Circuit of E-Cradle

#### Advantages

- Design is simple.
- It is of low cost.
- Since, working on very low voltage, hence, it does not act as a danger to the baby.
- This system helps parents and nurses to take care of babies without physical attention.
- It helps in keeping the baby in hygienic condition.

#### Disadvantages

- It may start at any voice greater than set preset value of sound level.

#### 5. Future Aspects

This system can be enhanced with more features like with baby rotating toy with music and camera. Parents can monitor their baby live via 3G. Also, instead of Alarm, parents can be intimated by sending an SMS to the parents' mobile phone.

#### 6. Conclusion

Looking after babies is hard problem worldwide. Babies are society future. This system emphasizes the importance of child care. The above designed system is economical and user friendly and very useful for working parents and nurses.

With the development of technology day to day work has been eased for parents along with baby care. Otherwise, mother's lap would be best cradle for baby.

#### 7. Reference

- [1]. Yang Hu; WeihuaGui; , "Adaptive Sway Control for Baby Bassinet Based on Artificial

Metabolic Algorithm” School of Information Science and Engineering, Central South University, China.

[2]. Marie R. Harper; La Mirada; Maxine R. Blea; , “Automatically rocking baby cradle”, US 3769641, Date of Patent: Nov. 6,1973.

[3]. Gim Wong, “Automatic baby crib rocker” US 3952343, Date of Patent: Apr. 27,1976.

[4]. Chau-Kai-Hsieh; Chiung Lin; Taiwan; , “Baby Cry Recognizer” US 5668780, Date of Patent Sep. 16,1997.

[5]. Anritha Ebenezer; Anupreethi. S; , “Automatic Cradle Movement for Infant Care” Undergraduate Academic Research Journal (UARJ), ISSN : 2278 – 1129, Vol.-1, Issue-1, 2012.

[6]. Steven Bang; Richard Lam; NatalliaLoCicero; , “Rock Me Baby: The Automatic Baby Rocker” Project for, San Jose State University, Department of Mechanical and Aerospace Engineering, May 17, 2011.

[7] MishaGoyal, Dilip Kumar, “Automatic E-Baby Cradle Swing Based On Baby Cry”, IJCA, June, 2013

## AUTHORS BIOGRAPHY

**Dr. Kshitij Shinghal** has 15 Years of experience in the field of Academic and is actively involved in research & development activities. He started his career from MIT, Moradabad. Presently he is working as an Associate Professor & Head, Deptt of E&C Engg., at MIT Moradabad. He has published number of papers in international & national journals, conferences and seminars. He has guided two Masters, more than sixty students of B.Tech and three M.Tech Thesis. He is an active Member of Various Professional Societies such as ISTE, IACSIT, IAENG etc.



**AmitSaxena** has 13 Years of experience in the field of Academic. He obtained his Bachelor’s degree in Electronics & Communication Engineering from I.E.T., Rohilkhand University, Bareilly and Mastersdegree (VLSI Design) in 2009 from UPTU, Lucknow. He started his career from MIT, Moradabad. Presently he is working as an Assistant Professor, Deptt of E&C Engg., at MIT Moradabad. He has published



number of papers in international & national journals, conferences and seminars. He is an active Member of Various Professional Societies such as ISTE, IACSIT, IAENG etc.

**NitinBhatnagaris** pursuing B.Tech in Electronics & Communication Engineering from Moradabad Institute of Technology, Moradabad. Area of interest includes Robotics & Embedded Systems.



**NiketKumar Tiwariis** pursuing B.Tech in Electronics & Communication Engineering from Moradabad Institute of Technology, Moradabad. Area of interest includes Robotics & Embedded Systems.



**ShubhamBhatnagaris** pursuing B.Tech in Electronics & Communication Engineering from Moradabad Institute of Technology, Moradabad. Area of interest includes Robotics & Embedded Systems.



**Shushant Kumar** is pursuing B.Tech in Electronics & Communication Engineering from Moradabad Institute of Technology, Moradabad. Area of interest includes Robotics & Embedded Systems.

